

CONSTRUCTION

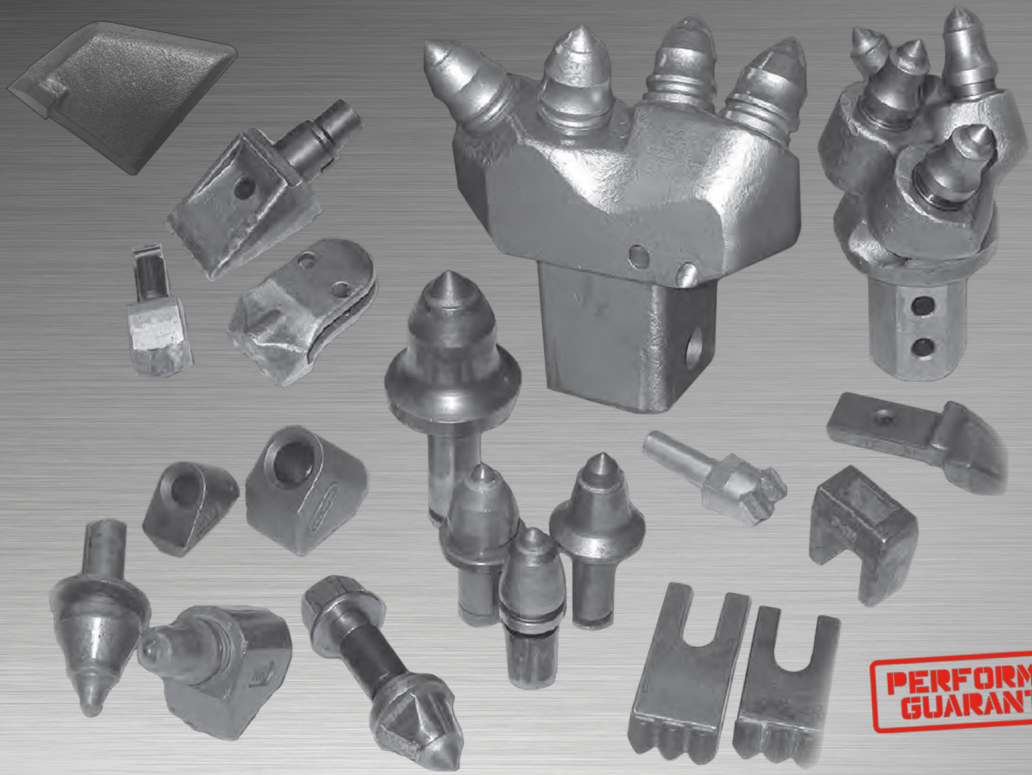

**PERFORMANCE
GUARANTEED**

TABLE OF CONTENT

CONICAL PICKS	1-4
DRILLING TOOLS	5-6
WELD ON TEETH	6-9
EMF FLAT AUGER TEETH	10-11
EMF FISHTAIL & AUGER PARTS	11-14
FLAT CUTTER PICKS & BLOCKS	15
AUGER, TAPER FIT & BUCKET TEETH ...	16-20
POCKETS, SHANKS, BLOCKS	17-21
INSTALLATION & REMOVAL TOOLS	22
WEAR ITEMS & CASING ITEMS	23
PILOT BITS	24-25
TRICONE BITS	26
ADAPTERS	27
WOMBAT	28
API THREAD REAIRING	29

CONICAL PICKS

CP01 - 55 Series

Full Body, 16mm Cone Cap

BLOCK: C055

100

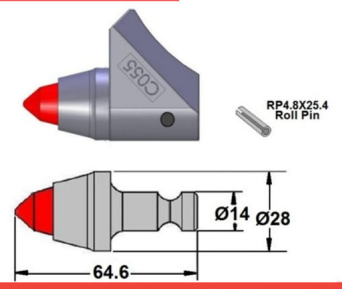

CP10 - 74 Series

Grooved/Narrow Body, 12mm S/Cone Insert

BLOCK: C-1S

75

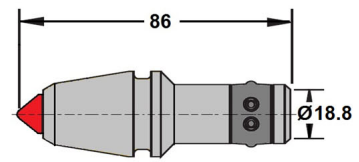

CP13 - 74 Series

Grooved/Narrow Body, 16mm S/Cone Cap

BLOCK: C-1S

75

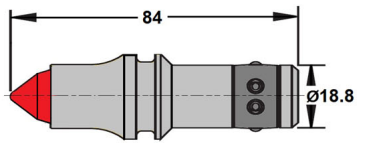

CP20B - 76 Series

Grooved/Narrow Body, 12mm Cone Insert

BLOCK: C-2S

75

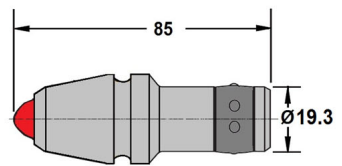

CONICAL PICKS

CP23L - 76 Series
Grooved/Narrow Body, 16mm D/Cone Cap

BLOCK: C-10 

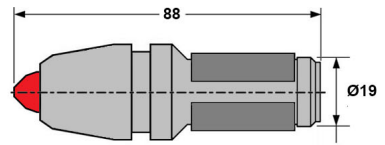

CP34L - 86 Series
Flanged Head Body, 16mm D/Cone Cap

BLOCK: B-3 

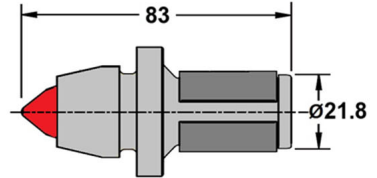

CP30B - 86 Series
Grooved/Narrow Body, 12mm Cone Insert

BLOCK: B-3 

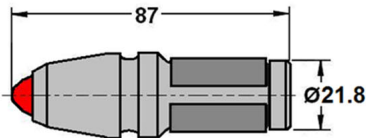

CP35L - 86 Series
Flanged Head Body, 12mm Cone Insert

BLOCK: B-3 

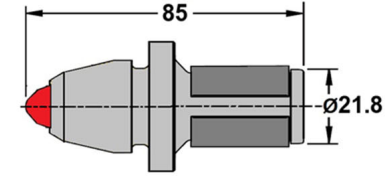

CONICAL PICKS

CP41 - 99 Series
Grooved/Narrow Body, 12mm Cone Insert

BLOCK: B-4 

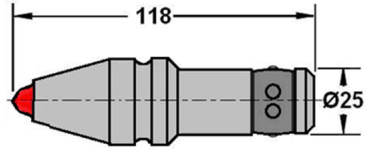

CP43 - 99 Series
Grooved/Slim Body, 12mm S/Cone Insert

BLOCK: B-4 

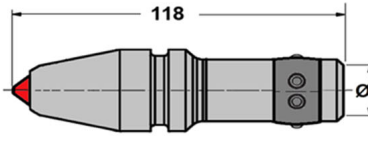

CP42 - 99 Series
Grooved/Narrow Body, 16mm Cone Insert

BLOCK: B-4 

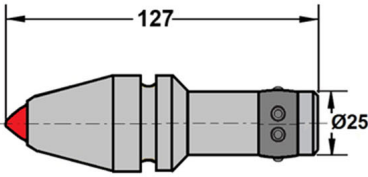

CP60 - 116 Series
Stepped Shank, Grooved Narrow Body, 22mm Ballistic Insert

BLOCK: C-6S 

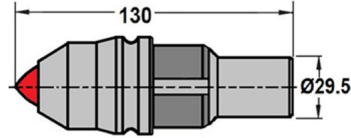

CONICAL PICKS

CP64 - 116 Series
Carbide Tooth for Hard Conditions

BLOCK: C-4 

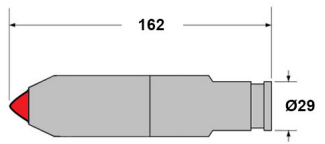

CP70 - 118 Series
Straight Shank, Full Body, 17mm S/Cone Insert

BLOCK: B-7B 

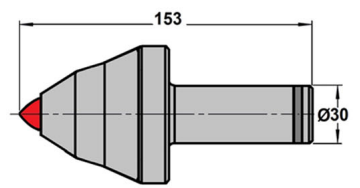

CP60-19L - 116 Series
Carbide Tooth with Pocket Protection for Hard Conditions

BLOCK: C-4 

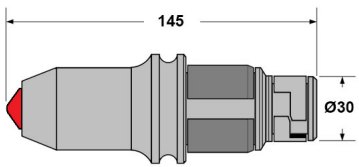

CP75 - 118 Series
Straight Shank, Mid Retainer, 17mm Mushroom Insert

BLOCK: B-7B 

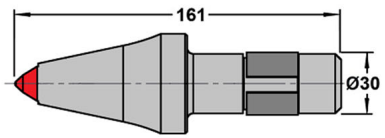

DRILLING TOOLS

CPF70
Flat Pick

HOLDER: C-6F

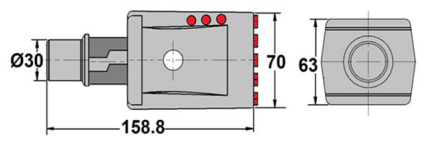

QCB39

Quick Change Bar with Carbide Insert

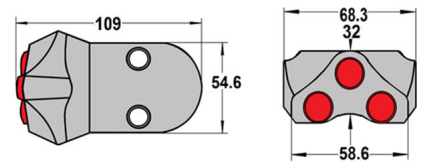

CPF150
Flat Pick

HOLDER: C-3S / B-3S

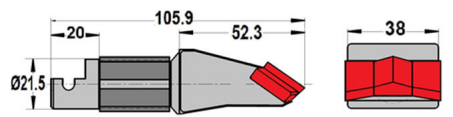

WBA55

Weld on Bar with Carbide Insert

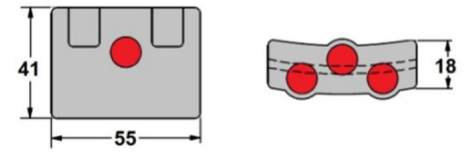

DRILLING TOOLS

WBA04

Weld On Bar with Carbide Insets

HOLDER: C-6F

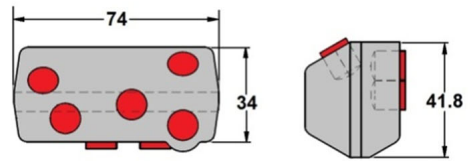

HDD-12DCI-25-45

Weld On 12mm Insert Tooth, Height 25mm

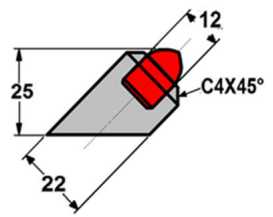

WELD ON TEETH

HDD-12DCI-32-45

Weld On 12mm Insert Tooth, Height 32mm

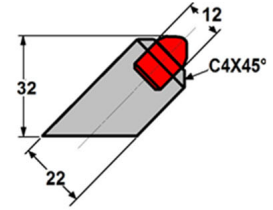

HDD-16DCC-25-45

Weld On 16mm Cap Tooth, Height 25mm

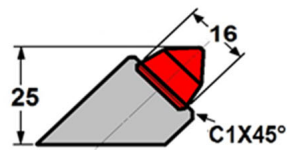

WELD ON TEETH

HDD-16DCC-32-45

Weld On 16mm Cap, Tooth Height 32mm

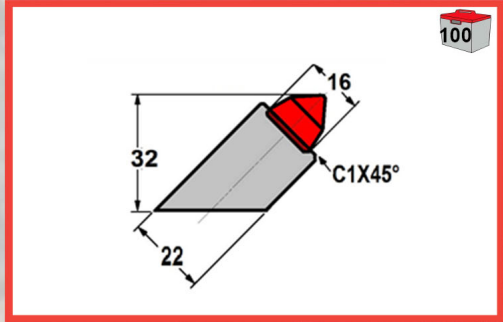

EM405-S

Weld-On Tooth, Height 25.5mm

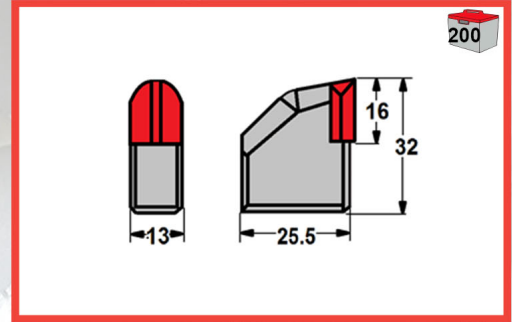

HDD-16DCC-33-90

Weld On 16mm Cap, Height 33mm, Angle=90

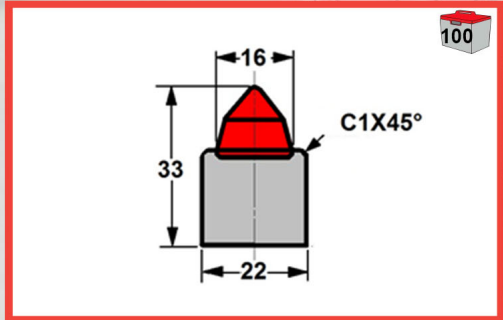

EM405

Weld-On Tooth, Height 44mm

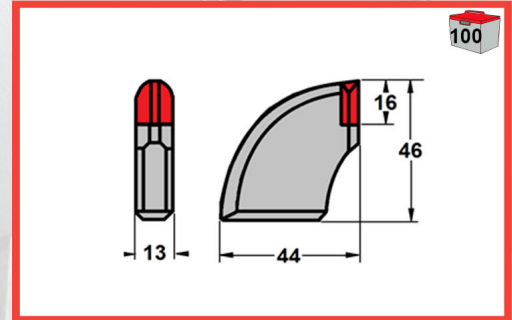

WELD ON TEETH

EM405-22

Weld-On Tooth, Height 36.5mm

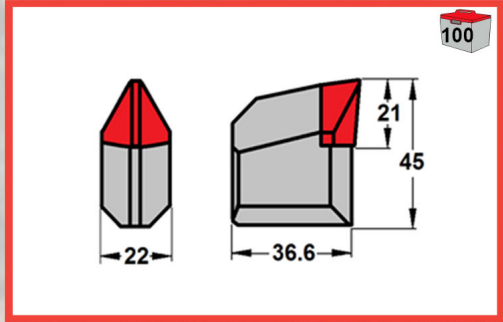

EM405-22L

Weld-On Tooth, Height 57mm

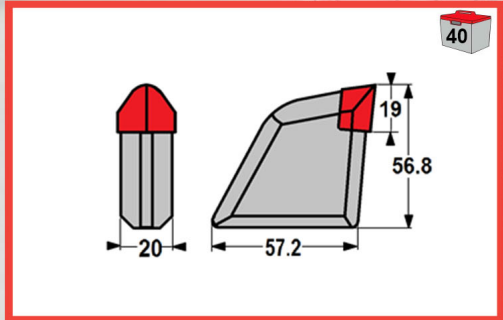

EMF505 - 35 SERIES

Plain Dirt Tooth

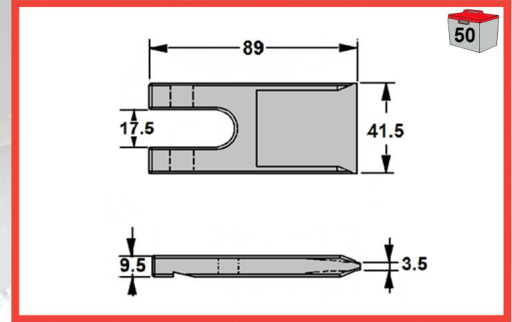

EMF506 - 35 SERIES

Plain Chisel Tooth

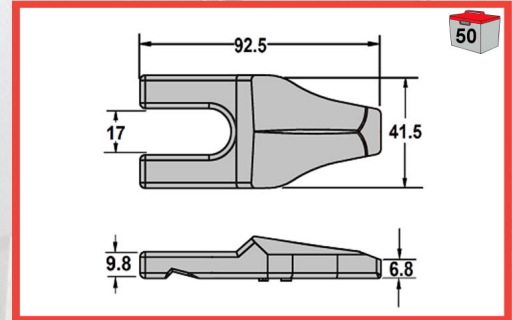

WELD ON TEETH

EMRE1

Replacement weld-on carbide segments

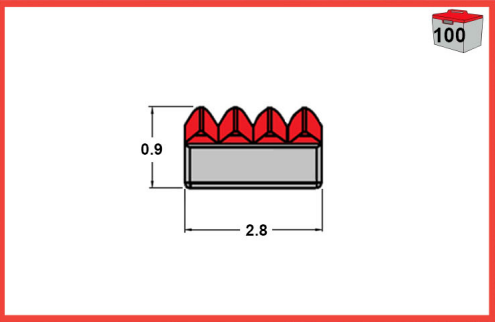

HDD-12DCI-25-45

Weld On 12mm Insert Tooth, Height 25mm

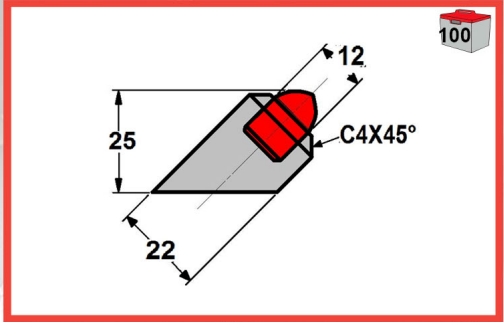

EMF FLAT AUGER TEETH

EMF508 - 35 SERIES
Chisel Tooth, Carbide Tipped

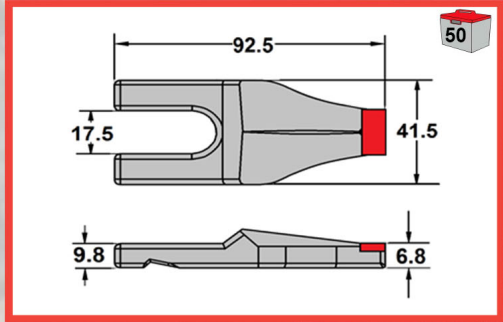

EMF527 - 35 SERIES
Flat Tooth, Carbide Tipped

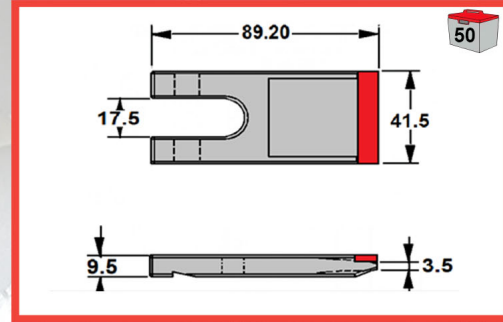

EMF509 - 35 SERIES
Chisel Tooth, Carbide Tipped, FW Insert

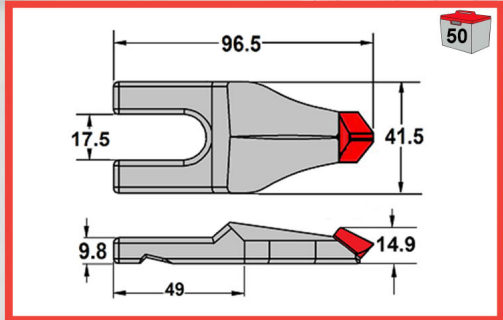

EMF535 - 35 SERIES
Heavy Duty, Triple Teeth, Carbide Tipped

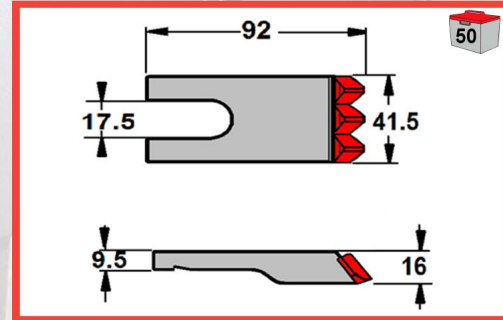

EMF FLAT AUGER TEETH

EMF535-14 - 35 SERIES

Heavy Duty, Triple Teeth, Carbide Tipped

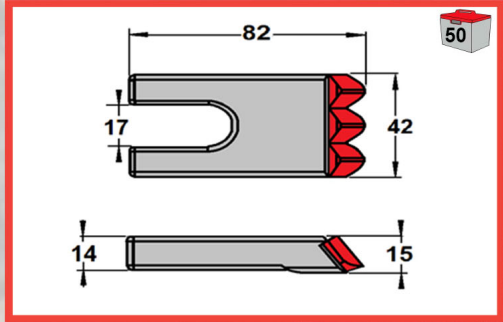

EMF FISHTAIL & AUGER PARTS

EMF590

SB45 Plain, Fishtail Pilot

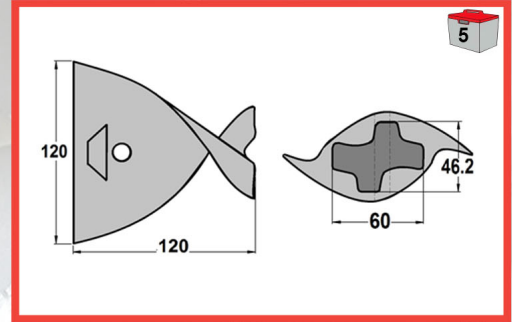

EMF580

SB35 Plain, Fish Tail Pilot

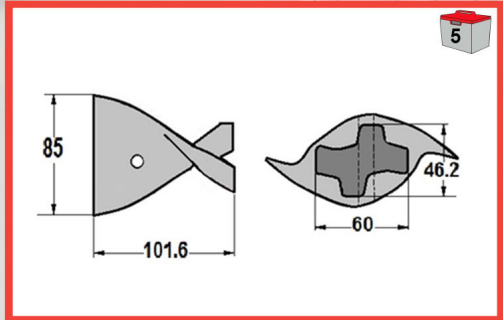

EMF610

SB35 TC, Fish Tail Pilot, Carbide Tipped

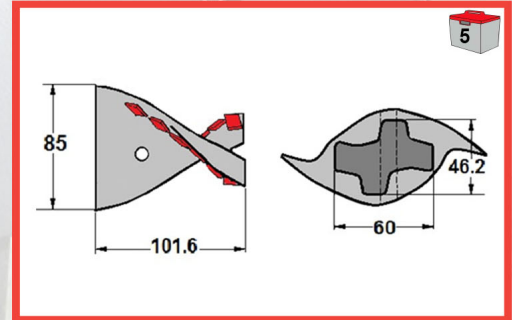

EMF FISHTAIL & AUGER PARTS

EMF611
SB45 TC, Fish Tail Pilot, Carbide Tipped

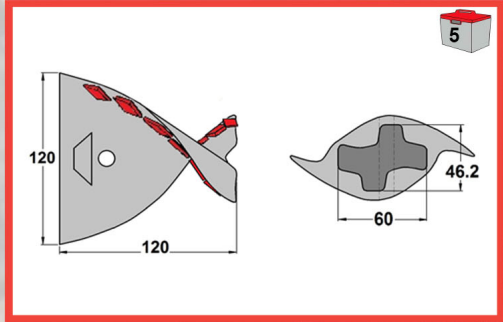

EMF612
SB35 HD TC, Fish Tail Pilot, Carbide Tipped, Heavy Duty

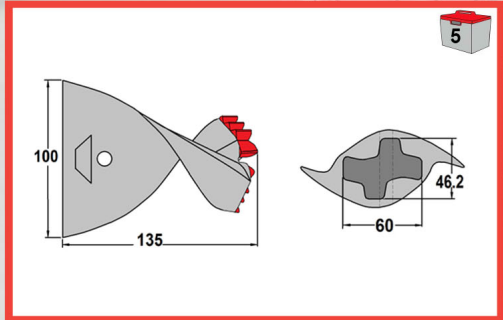

EMF635
SB35 Weld On Drive Lug

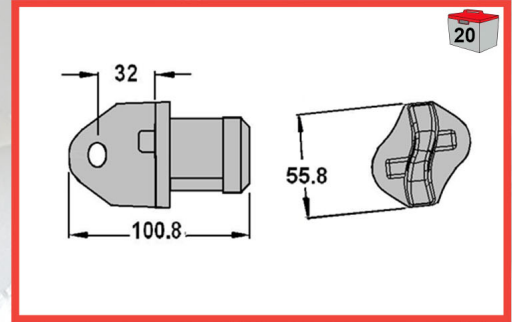

EMF660 - 35 SERIES
T36, Tooth Holder

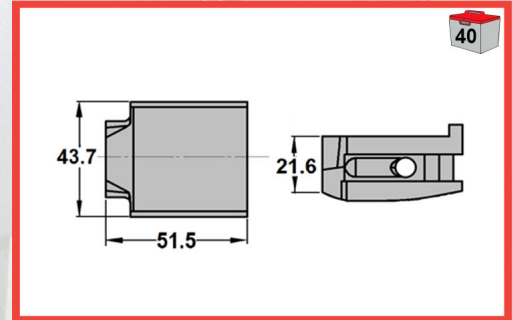

FLAT CUTTER PICKS & BLOCKS

EM410A-F
Flat Cutter Pick, 14mm Insert

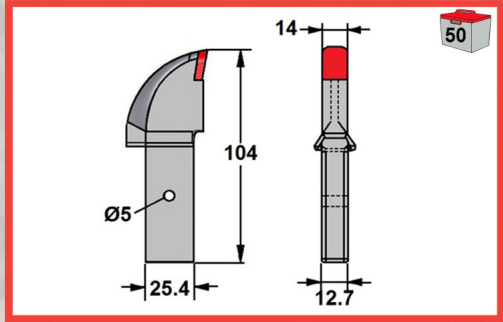

EM411-F
Flat Cutter Pick, 19mm Insert

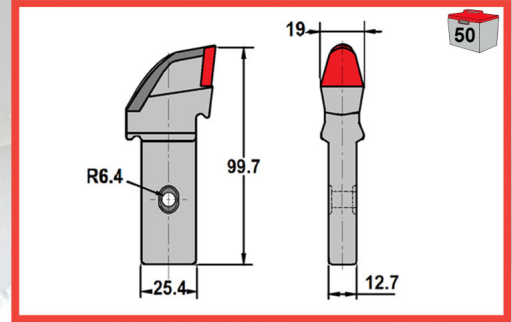

EM411-P
Flat Cutter Pick, 14mm Insert (FW8B)

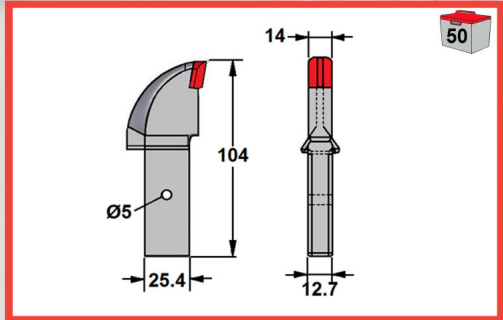

F-2S
Flat Cutter Pick, Block Forged

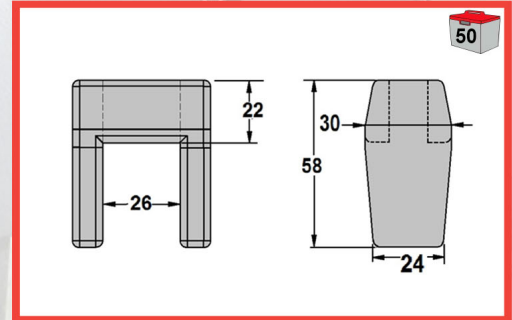

FISHTAILS

EM600TF
Tri Flow Pilot, 1-3/4" Square Shank.



EMDB6 QUAD
Quad Dirt Pilot, 2-1/2" Square Shank.

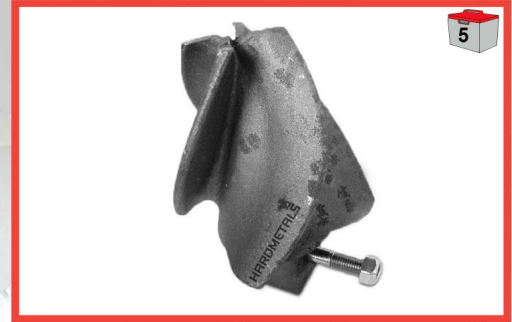

EMDB6
Dirt Pilot, 2-1/2" Square Shank.



EMDB7 QUAD
Quad Dirt Pilot, 4" Square Shank.



FISHTAILS

EMDBS250
Fishtail, 2-1/2" Square I.D. Box.



EMMM1
Fishtail, 1-3/4" Square Shank.



EMDBHS3
Fishtail, 3" Square I.D. Box.



EMF238
Fishtail, 2-3/8" Pin.



AUGER TEETH **TAPER FIT TEETH**

EMP211
Dirth Tooth for Hard Conditions, Single Offset

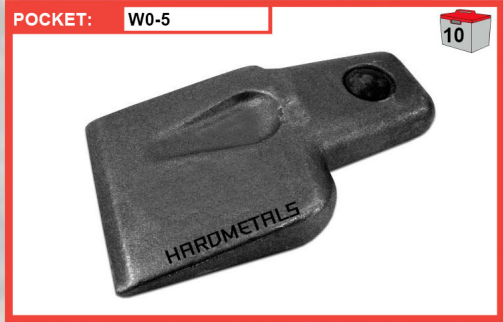

EMP132
Dirth Tooth for Regular Dirt Conditions



EMP299
Dirth Tooth for Hard Conditions "Tiger Paw"



EMP134
Dirth Tooth for Regular Dirt Conditions, Double Offset



AUGER TEETH **TAPER FIT TEETH**

EMP60
Dirt Tooth for Regular Conditions

POCKET: W0-1

60



POCKETS

EMPW0-5
Pocket

10

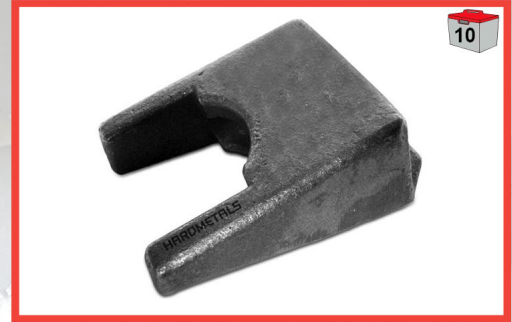

EMP201
Dirt Tooth for Regular Dirt Conditions

POCKET: W0-5

15

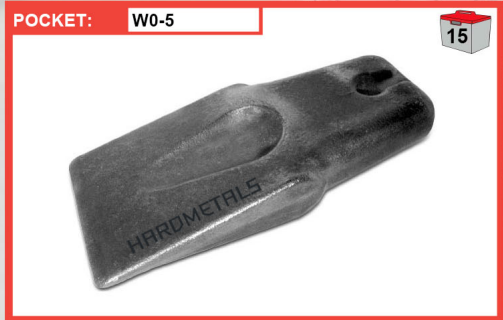

EMPW0-1
Pocket, commonly used on Belling Tools

10



AUGER TEETH

BUCKET TEETH

Flared Top Pin Tooth.
EMX220F



Side Pin Shank.
EMCL100123



Front End Side Pin Loader Tooth.
EM550LOD



Top Pin Shank.
EM84518



BUCKET TEETH **AUGER TEETH**

EM220WN
Top Pin Shank.



OTHER TEETH **AUGER TEETH**

EMBFZ69
Non Rotating Tooth for Regular Dirt Conditions.



EMBFZ70S
Non Rotating Carbide Tooth for Hard Conditions.



EMBFZ70
Non Rotating Carbide Tooth for Hard Conditions.



OTHER TEETH

AUGER TEETH

EMWS39PM
Pocket



EMWS39A
Alloy Carbide Casing Tooth for Hard Conditions.



EMWS39S
Standard Carbide Casing Tooth for Hard Conditions.



EMWS46M
Heavy Duty Carbide Casing Tooth for Hard Conditions.



POCKETS & BLOCKS

EMRVH85
Block



EMBHR39HD
Single Shoulder Heavy Duty Block.



EMBHR39
Single Shoulder Block.



EMB75CEC
Double Shoulder Block.



INSTALLATION & REMOVAL TOOLS ACCESSORIES

EMC30
Puller. Used with the #EMC31HD teeth.



EM66
Puller. Used with the #EMB47K19-L & #EMB47K19-S teeth.



EMC123
Puller. Used with the #EMSC101, #EMSL02, #EMC21HD & #EMRL08 teeth.



EMKRP4
Snap Ring Pliers. Used with the #EMC41 teeth.



WEAR ITEMS **ACCESSORIES**

EMAFC38
Wear Pad



ACCESSORIES **CASING ITEMS**

EMBRV08
Caisson Screw



EMBRV02
Conical Joint



EMBRV32
Caisson Key



PILOT BITS

EM434RP
4-3/4" Step Pilot, 2-3/8" Pin.



EM238
4 Tooth Pilot, 2-3/8" Pin. Takes #EMSC1-01 teeth.



EM312
4 Tooth Pilot, 3-1/2" Pin. Takes #EMC31-HD teeth.



EMMM2
4 Tooth Pilot, 1-3/4" Square Shank. Takes #EMSC1-01 teeth.

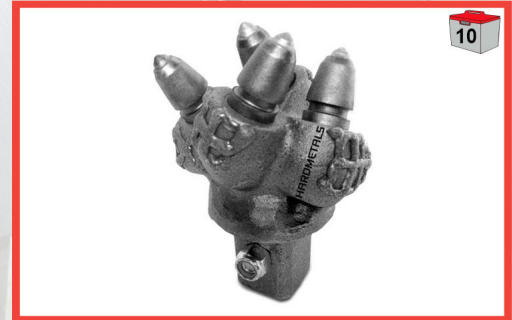

PILOT BITS

EM3583WP
3-5/8", 3 Way Pilot, HDF Box.



EMRP4
4 Tooth Pilot, 4" Square Shank. Takes #EMB47K19-L teeth.

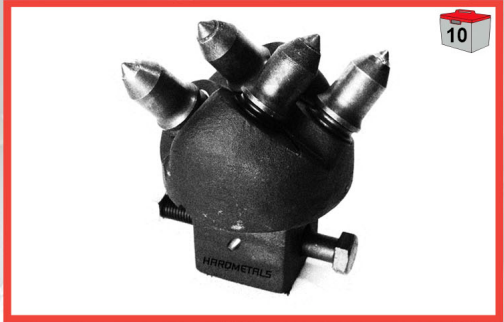

EMRP9
4 Tooth Pilot, 3-1/2" Pin. Takes #EMC31HD teeth.

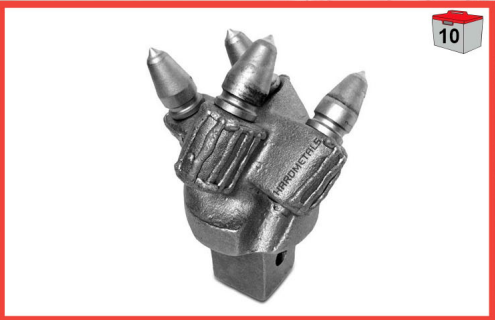

EMGA
Gatorback bit, Good for environmental, waterwells, mining, geothermal drilling



TRICONE BITS

EMTC
Tricone, Carbide Button Bit.



EMTS
Tricone, Steel Tooth Bit.



EMTP
Tricone, PDC bit



Contact us directly for information about variety of Tricone bit sizes or types.

ADAPTERS

EMA47
Adapter with 4" Square I.D. x 7" Round O.D.



EMA48
Adapter with 4" Square I.D. x 8" Round O.D.



HOLE OPENERS

Wombat
Wombat Hole Openers, from 4" to 16"

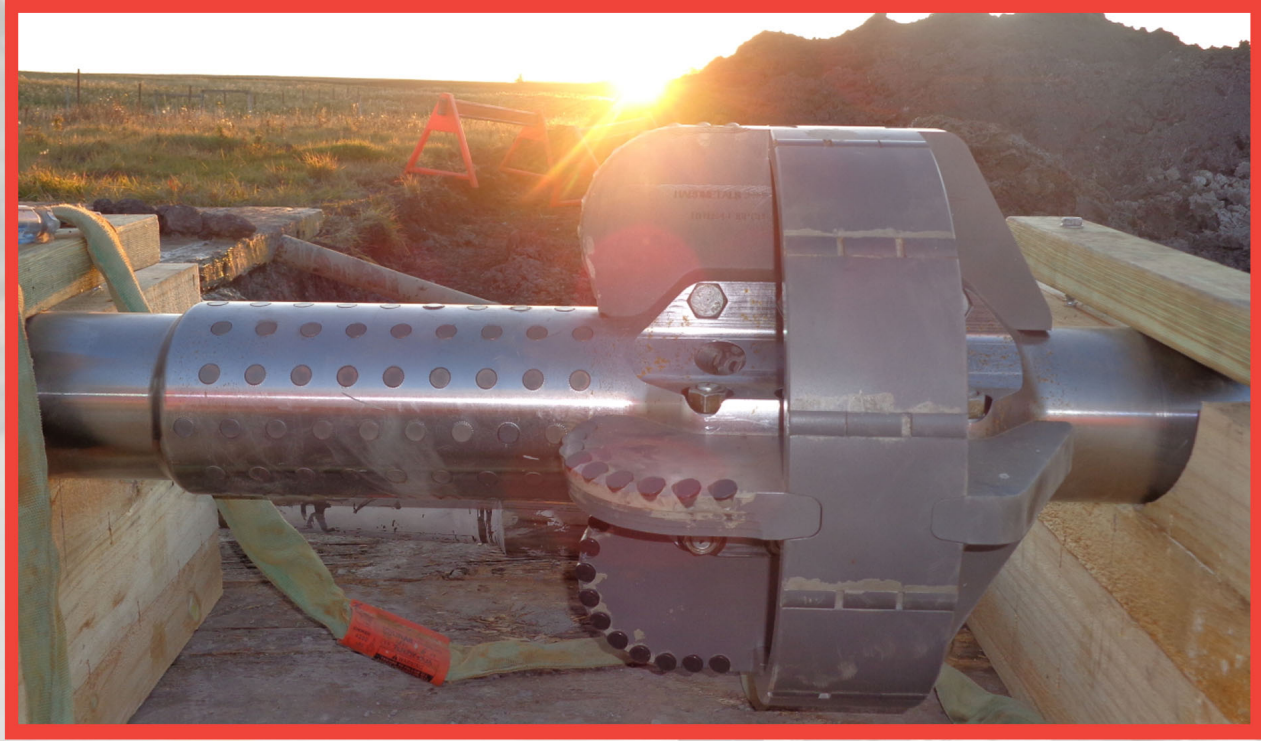

REPAIRING

Repairing
API Thread repairing

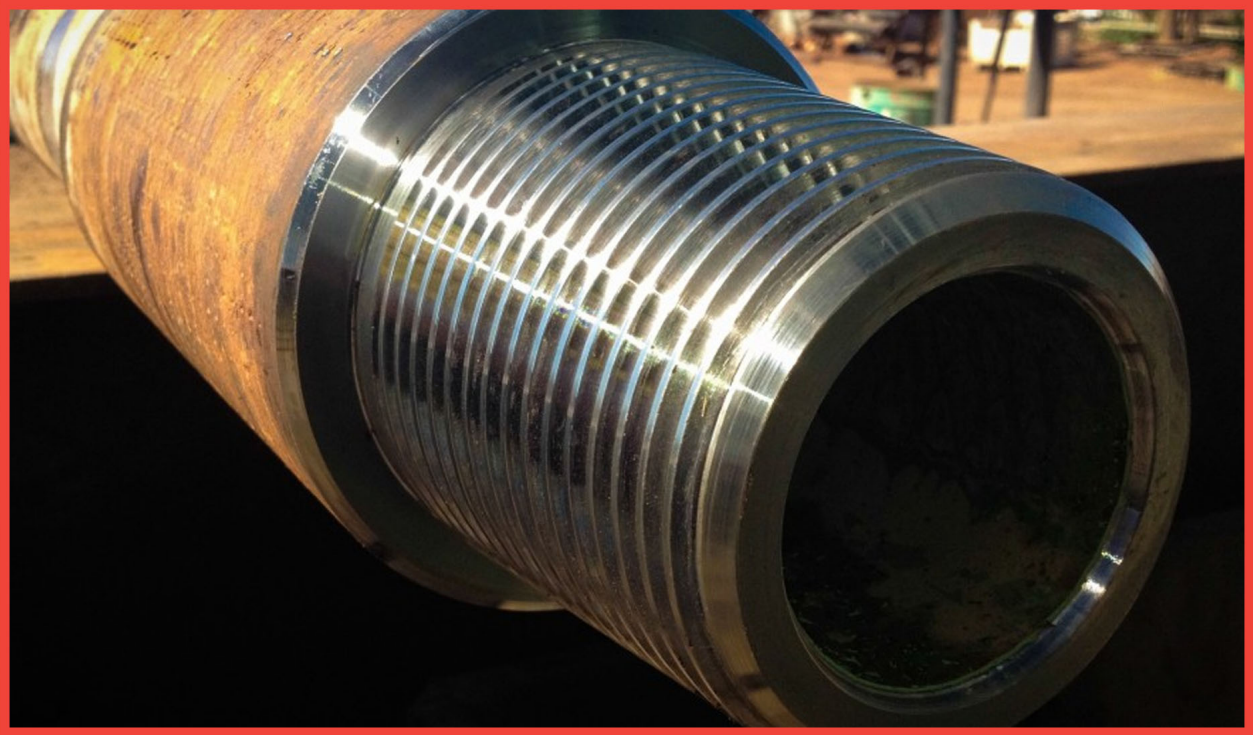

CONCACT INFORMATION:

HARDMETALS CANADA INC.

Address:

Unit 3, 9550 114th Avenue SE
Calgary, T3S 0A5, Canada

Phone:

+1 403 615 6163

Email:

ervin@hardmetals.ca

Web:

www.hardmetals.ca